

Valvola di blocco pilotata a doppio effetto a sfera o a cono
Double effect, pilot operated check valve, ball or poppet type
 mod. **VBD-SF** (sfera – ball) / **VBD-SP** (cono – poppet)

Versione con corpo in alluminio o in acciaio
Aluminum or steel body version

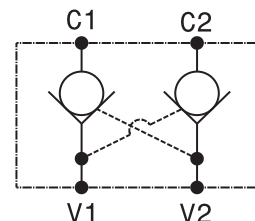

Modello Type	Rapporto di pilotaggio Pilot ratio	Portata massima Max Flow	Pressione massima Max pressure	Pressione di apertura Cracking pressure
VBD-14-SF	4:1	20 l/min 5.3 gpm	350 bar 5000 psi	3 bar 43 psi
VBD-38-SF	4:1	35 l/min 9 gpm	350 bar 5000 psi	3 bar 43 psi
VBD-12-SF	3:1	50 l/min 13 gpm	350 bar 5000 psi	1 bar 14.5 psi
VBD-14-SP	4:1	20 l/min 5.3 gpm	350 bar 5000 psi	3 bar 43 psi
VBD-38-SP	4:1	35 l/min 9 gpm	350 bar 5000 psi	3 bar 43 psi
VBD-12-SP	3:1	50 l/min 13 gpm	350 bar 5000 psi	1 bar 14.5 psi
VBD-34-SP	4:1	80 l/min 21 gpm	250 bar 3600 psi	0.5 bar 7.2 psi

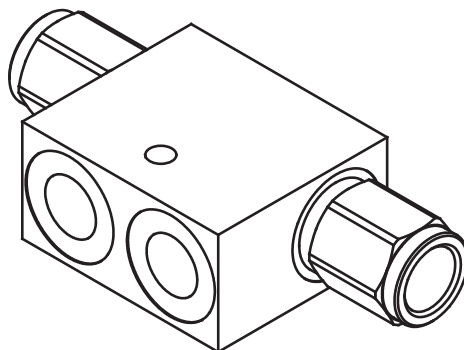
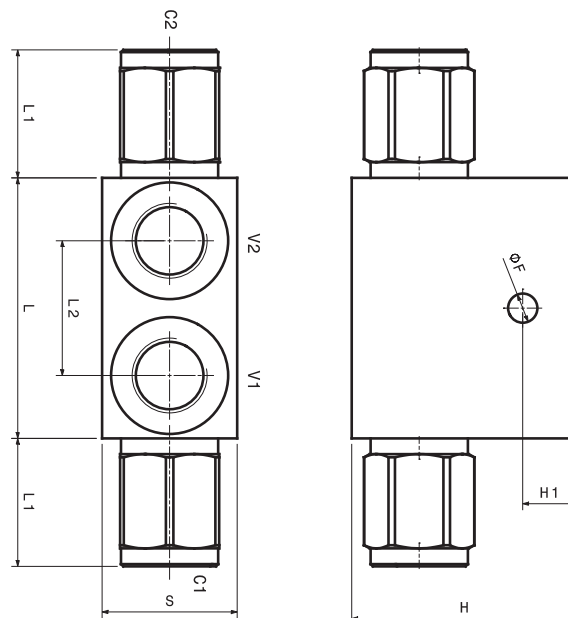

Dati e tarature ottenuti usando olio con viscosità 30 cSt a 50°C
Performances and calibrations are carried out by using hydraulic oil with 30 cSt viscosity at 50°C

Viscosità consigliate Recommended viscosity	10 ÷ 420 cSt
Temperature di lavoro Working temperature	-20 ÷ +90 °C
Filtrazione assoluta Absolute filtration	25 µ

Dimensioni Dimensions	C V	L	L1	L2	H	H1	S	F
VBD-14-SF	1/4" GAS	58	27	35	40	12	25	6.5
VBD-38-SF	3/8" GAS	58	29	30	50	12	30	6.5
VBD-12-SF	1/2" GAS	70	35	35	50	12	35	6.5
VBD-14-SP	1/4" GAS	58	27	35	40	12	25	6.5
VBD-38-SP	3/8" GAS	58	29	30	50	12	30	6.5
VBD-12-SP	1/2" GAS	70	35	35	50	12	35	6.5
VBD-34-SP	3/4" GAS	100	40	50	60	15	40	8.5

Sigla di ordinazione / Ordering code

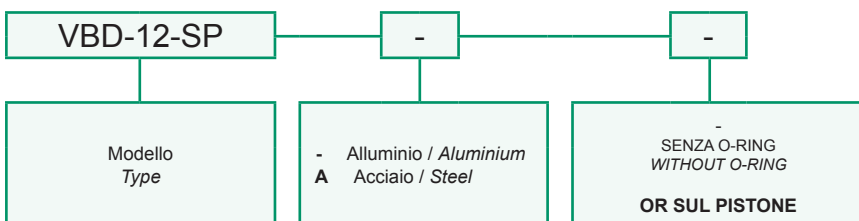

I dati non sono impegnativi, **CBF** si riserva di apportare modifiche senza preavviso.
The specifications are not binding, CBF reserves the right to introduce modifications without notice.